



INSTRUCTION MANUAL
Heto-Holten A/S
Weighmaster
ID:807205

Important user information

Please read this entire manual to fully understand the safe and effective use of this product.



In case you have any comments about this manual we will appreciate receiving them at:

Warranty and Liability

HETO-HOLTEN A/S guarantees that the product delivered has been thoroughly tested to ensure that it meets its published specifications. The warranty included in the conditions of delivery is valid only if the product has been installed and used in accordance with the instructions supplied by HETO-HOLTEN A/S.

HETO-HOLTEN shall in no event be liable for incidental or consequential damages, including without limitation, lost profits, loss of income, loss of business opportunities, loss of use, and other related exposures, caused by e.g. incorrect use of the product.

Symbols used in this manual

	WARNING Used in case of danger of a serious accident or when documentation needs to be consulted.
	NOTE Used to direct attention to a special item.

© Copyright 2001

HETO-HOLTEN A/S
Gydevang 17-19
DK-3450 Allerød
Denmark

Telephone +45 48 16 62 00
Fax +45 48 16 62 97
e-mail info@heto-holten.com

Home page: <http://www.heto-holten.com>

Table of contents

1.	Introduction	4
2.	Safety precautions	4
3.	Getting started	4
3.1.	Description – Principle of operation	4
4.	Installation	5
5.	Operation – control panel	5
6.	Working rules	6
6.1.	Working rules before work is started	6
6.2.	Working rules during work.....	7
6.3.	Working rules after work.....	7
7.	Technical description	7
8.	Technical data	9
9.	Property of materials	9
10.	Functional parts of the cabinet	10
11.	Maintenance	11
11.1.	Recommended maintenance.....	11
11.2.	Change of worn electrical parts	11
11.3.	Change of filters	12
12.	Recommended spare parts for Weighmaster	14
13.	Trouble-shooting	16
14.	Specific	16
14.1.	Exhaust to the outside.....	16
15.	Considerations for exhaust to the outside system	16

Enclosure: Declaration of conformity

1. Introduction

The Holten LaminAir Weighmaster-series are designed to provide protection of the operator, the surroundings and the work process itself against particle contamination.

The WEIGHMASTER is a specially designed cabinet with sloping front window.



WARNING

The WEIGHMASTER cabinets **must not be mistaken** for Class II safety cabinets.

2. Safety precautions

In order to avoid unintended wrong attendance please read this instruction manual carefully.

For the Holten LaminAir model WEIGHMASTER the following precautions should be noted!



WARNING

- Never operate the WEIGHMASTER cabinet with the cover of the fan removed. If the cover is off there is no personal protection and the fan will run with uncovered rotating blades.
- The WEIGHMASTER cabinet will not provide any protection for operator or surroundings against harmful gases or vapours without exhaust to the outside.

3. Getting started

3.1. Description – Principle of operation

A WEIGHMASTER cabinet consists of a confined workspace in which stable airflows provide protection against contamination from the surroundings and the operator.

A light sub-pressure in the work opening draws room air in through the work opening. The ingoing airflow prevents that emitted particles from the product or the work process are drawn into the surrounding rooms including the breathing zone of the operator.

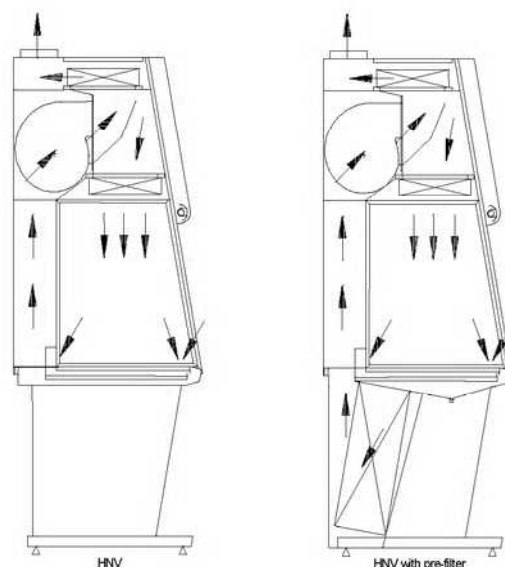

Figure 1. Principle of operation for Weighmaster.

4. Installation

1. Check that the dimensions of the unit make free access to the wanted site of installation possible. The minimum width is 800 mm.
2. The installation site for the unit should be without draught and should be selected so that frequent passing-by of persons in front of the work opening is avoided.
3. The tabletops of stainless steel are mounted over the trough.
4. Adjust the levelling screws on the stand so that the tabletop is horizontal.
5. Connect cabinet to mains.



WARNING

Prior to electric connection it must be checked that the mains supply corresponds to what is stated on the type plate. For increased safety the connection can be carried out as a fixed installation.

6. Valves for gases, vacuum or liquids are placed in a separate plate in the left or right side window. An authorised technician should carry out connection of these.



NOTE

Important - exhaust to the outside. Installation of exhaust to the outside involves many considerations and precautions. Please consult the specific part on exhaust to the outside for details.

5. Operation – control panel

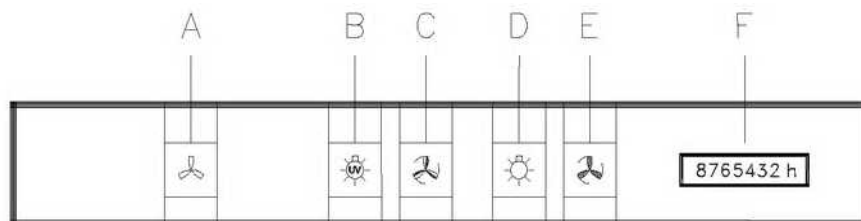

Figure 2. Control panel of Weighmaster.

- A. Alarm signal lamp.
- B. Pushbutton switch for UV-light.
- C. Pushbutton switch for changing between normal and reduced speeds and signal light (yellow) for reduced fan speed.
- D. Pushbutton with signal light (blue) for switching the light in the work chamber on/off.
- E. Pushbutton for start/stop of fan and signal light (green) for normal fan speed.
- F. Hour counter.

Re Red alarms light for insufficient flow. The velocity in the laminar flow is below the wanted minimum value. The green lamp **E** turns off when the alarm is on.

Re B Yellow lamp for UV-light, can only be activated when the main light is off.

Re C With the yellow switch it is possible to choose between normal and reduced fan speed. By operation at reduced speed the effectiveness of the product protection is also reduced.

When a product is handled in the unit it is therefore essential that the unit is operated at normal fan speed.

Operation at reduced speed is only to take place when the unit is not in use.

The use of reduced speed reduces the risk of contamination of the work chamber between handling of products.

Re D the work chamber lighting can be switched on and off.

6. Working rules

6.1. Working rules before work is started

- About 15 minutes before work is started the fan of the unit is switched on for operation at normal speed. A green control lamp indicates proper operation.
- The work chamber is to be carefully cleaned and disinfected. Use 70 % ethanol or the like. It is recommended to use special lint-free wipes. Use preferably aqueous disinfectants on the front window and the side windows - never use disinfectants containing chloroform (see list on allowed disinfectants in the Appendix). Use mainly soft cloths in order not to scratch the windows.
- Objects and remedies must be carefully cleaned or disinfected before being brought into the work chamber.
- Sash or push-up window is placed in working position and kept in that position during the entire work process.
- Necessary remedies for use during work must be placed within reach.
- Put on necessary personal clothes for protection of operator as well as product (e.g. gloves, masks, visors and general clean room clothing).
- Never perform any work with the fan at reduced speed.
- Place the product as far back in the work chamber as possible.
- Work with tranquil movements.
- Never overload the work chamber.
- Reduce the number of transports into and out of the work chamber.
- Avoid products or remedies with strong emission of heat.
- Do not place the cabinet in places with direct draught towards the work opening.
- Avoid placing the cabinet where many persons pass by.

6.2. Working rules during work

- For reliable operation it is important that the airflow conditions are as undisturbed as possible. Therefore, never overload the work chamber - only remedies necessary for the actual work should be placed in the work chamber.
- Place the product as far back in the work chamber as possible and min 2 cm behind the suction holes in the front of the tabletop. If the product is placed too close to the work opening, this may result in the formation of eddies which can create connection between the surroundings and the product.
- All work in the cabinet must be performed with tranquil movements. Quick arm movements in the work chamber may cause slipstreams that will draw contaminated air into the work chamber.
- The number of transports into the work chamber must be minimised. Transport of possibly contaminated material may in addition to the mechanical transport also cause formation of airflows that create connection between product and the contaminated surroundings.
- Heat-emitting products or remedies in the work chamber may disturb the wanted air movements.
- Around sources with strong emission of heat. The air is heated and thus creates an up current that will cause unstable conditions in the unidirectional flow. The protective effect of the cabinet may then disappear. Use preferably Bunsen burners with possible hand or foot-operated reduction of the effect.
- Draught towards the work opening can destroy the protective effect of the unidirectional flow.
- Passing-by of persons in front of the cabinet should be minimised. An onward movement in front of the work opening will create a pressure wave in front of the person. Passing-by of a person might therefore cause air from the surrounding space to be pressed into the work chamber. The effect is intensified the faster the person is moving and the closer to the opening the passing takes place.

6.3. Working rules after work

- Product, remedies and work chamber is again cleaned and has been finished disinfected carefully. Wipe off carefully and let the fan run for min 15 minutes without stop. If desired, the fan can be left running constantly at reduced speed.

7. Technical description

Air movements:

Via the work opening room air is drawn in through the perforated area in the front part of the tabletop. The vertical super-filtered airflow from the main filter separates in the middle so that the air is partly sucked down through the perforated area in the front part of the tabletop and partly sucked down through the perforated area in the rear edge of the work chamber. The total amount of air is mixed below the tabletops.

Prefilters EU 12 (special equipment):

The degree of detention is 99.99 % of particles with diameter 0.3 µm or greater (DOP-test). (The mixture of air from the work chamber and the work opening is filtered).

Fan:

The air is led to the fan placed in the top of the unit. Here an increase of pressure is applied to the air. The fan is of a self-compensating type and has thus only an insignificant drop in the quantity of air by an increase in back-pressure. By means of a built-in transformer the fan can be made to operate with increased power.

The air is then led to the pressure plenum. A part of it is exhausted to the room through exhaust filters. The rest is led over the main filter and forms the unidirectional flow in the chamber.

Exhaust filter:

Filter efficiency 99.999 % of particles with diameter 0.3 μm or greater (DOP-test).

Main filter:

Filter efficiency 99.999 % of particles with diameter 0.3 μm or greater (DOP-test).

8. Technical data

	WEIGHMASTER 2436	WEIGHMASTER 2448	WEIGHMASTER 2460	WEIGHMASTER 2472
Length	965 mm	1265 mm	1565 mm	1865 mm
Diameter outlet	Ø 200 mm	Ø 200 mm	Ø 200 mm	Ø 200 mm
Capacity of trough	7.5 l	10 l	12.5 l	15 l
Quantity of exhaust air (nominal)	405 m ³ /h	540 m ³ /h	675 m ³ /h	810 m ³ /h
Dry heat emitted (recirculation to room) max	434 W	555 W	693 W	833 W
Dry heat emitted (recirculation to room) nominal	384 W	490 W	613 W	735 W
Dry heat emitted (exhaust to the outside)	56 W	75 W	94 W	113 W
Mains voltage	220(115*) V	220(115*) V	220(115*) V	220(115*) V
Mains frequency	50(60*) Hz	50(60*) Hz	50(60*) Hz	50(60*) Hz
Current intensity	2 Amp	2 Amp	3,5 Amp	3,5 Amp
Max load on wall sockets	6 Amp	6 Amp	6 Amp	6 Amp
Required mains cut-out	10/16 Amp	10/16 Amp	10/16 Amp	10/16 Amp

*) Optional

9. Property of materials

Subjects	Material	Treatment
Front windows and side windows	Clear polycarbonate	
Window frames	PVC	
Upper part, return duct and bottom part	Mild-steel plate ST 1203 DIN 16023	60 µm polyester coating pre- treated to corrosion class 1
Stand	Iron pipe	60 µm polyester coating pre- treated to corrosion class 1
Trough, tabletops and suction gate	Stainless steel AISI 304	Polished

10. Functional parts of the cabinet

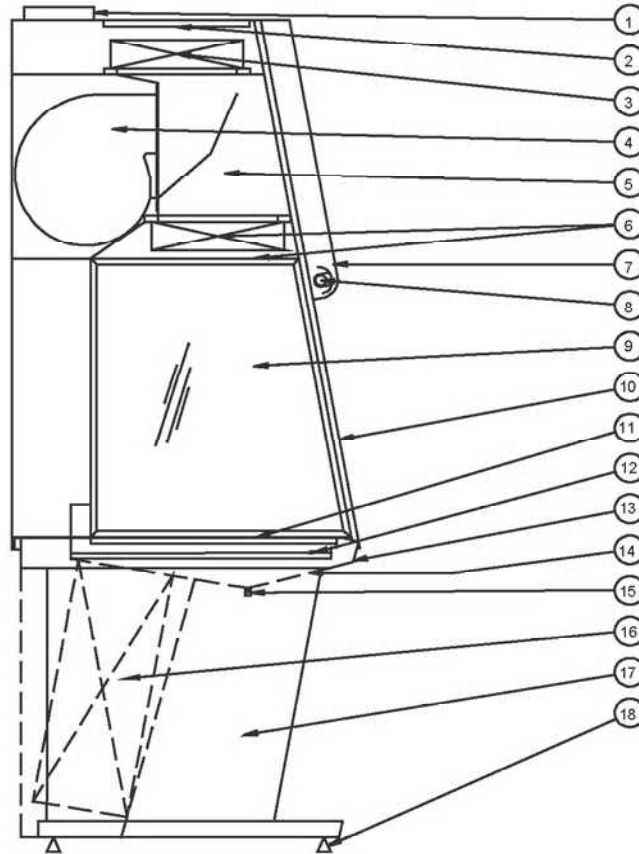

- | | |
|---|---|
| (1) : Exhaust stub | (10) : Sash or push-up front window |
| (2) : Exhaust filter cover | (11) : Tabletop |
| (3) : Exhaust filter | (12) : Prefilter EU 3 |
| (4) : Fan | (13) : Trough |
| (5) : Pressure chamber and air distributing plate | (14) : Trough at prefilter EU 12* |
| (6) : Downflow filter and distributing plate | (15) : 1/2" Drain valve at prefilter EU 12* |
| (7) : Control panel | (16) : Pre filter EU 12* |
| (8) : Light fittings | (17) : Stand |
| (9) : Side window | (18) : Levelling screws. |

*) Optional extras.

11. Maintenance

11.1. Recommended maintenance

Daily:

The work area is disinfected. Also lift the tabletops and carefully wipe the under side and the trough.

Weekly:

Wipe the exterior of the unit with a mild detergent of household type. Antistatic spray can be used for cleaning the front window.

Regularly:

Reliable operation of the safety cabinet and compliance with standards are based on the following conditions:

1. Correct air velocities.
2. Efficiency of the installed HEPA-filters.
3. Tightness of the construction.

	NOTE These parameters should thus be tested by a qualified technician after approximately 5000 hours of operation or at least once a year. On the right gable of the lamp shield there is a label stating the time for the next service check-up.
---	---

Testing of correct air velocities: Involves measurement of air velocities in the work opening as well as measurement of air velocities in the vertical laminar flow (see also the enclosed test report).

Testing of the efficiency of the installed HEPA-filters: By means of special measuring equipment - photometer or particle counter - the degree of detention of the filters is tested (see also the enclosed test report).

Testing of the tightness of the construction: All areas of the safety cabinet with positive pressure compared to the surroundings are tested for tightness (see also the enclosed test report).

Contact your supplier for further information on test procedures.

11.2. Change of worn electrical parts

Light tubes incl. starter and choke coil, pressostat, control panel and electrical plate are placed behind the lamp shield.

When changing these parts the two bottom fixing screws of the lamp cover are removed, the lamp cover is lifted by the hand. Afterwards, the lamp cover is refitted and screwed on.

Transformer and mains fuse are placed in a separate compartment in the right side of the top of the unit. When changing these the screw to the lid is loosened and after the change the lid is refitted and screwed on.

**WARNING**

If there is exhaust to the outside the lid to the electrical compartment should be sealed.

See spare parts list for specification of electrical parts.

11.3. Change of filters

The cabinet is disinfected before the filters are changed.

Used filters are immediately placed in suitable containers and delivered to destruction together with the other infectious waste from the laboratory.

**WARNING**

Please make sure that the cabinet is neutralised or disinfected so that filter change can be done without any danger.

Change of pre filter (optional equipment):

1. Switch on the fan.
2. Remove the whole of the tabletop.
3. Cover the filter openings on half of the filters with tape.
4. Cut through the mounting tape between the individual filters.
5. Pull out one filter at a time.
6. Cover the filter openings on the remaining filters with tape.
7. Pull out one filter at a time.
8. Insert new filters and fasten them by means of special tape.
9. Switch off the fan.

Change of main filter:

1. Push up the window.
2. Dismount the distributing plate.
3. Loosen the filter and remove it.
4. Insert new filter.
5. Fasten the filter to 3 mm gasket compression.
6. Refit the distributing plate.

Change of exhaust filter:

1. Cut up the silicone for the exhaust filter cover.
2. Dismount the exhaust filter cover.
3. Loosen the filter and remove it.
4. Insert new filter.
5. Fasten the filter to 3 mm gasket compression.
6. Refit the exhaust filter cover, seal the cover.

After any filter change do the following:**Test:**

- Correct air velocities.
- Efficiency of the installed HEPA-filter.
- Tightness of the construction.

See spare parts list for specification on filters.

**WARNING**

When changing filters we recommend you to wear protective garments, surgical gloves and filter mask with installed HEPA-filter.

12. Recommended spare parts for Weighmaste

WEIGHMASTER 2436				
Description	Amount	Make	Specifications	Holten no.
Exhaust filter	1 pcs	Camfil	MDLA-GW-305x914x66-01 PU	95200513
Main filter	1 pcs	Camfil	MDLA-GW-305x914x66-01 PU	95200513
Light tube	1 pcs	Phillips	TLD 30/83	844035
Starter	1 pcs	Osram	ST 111, 220-240 V-4-80W	844053
Fuse cut-out	1 pcs	Osram	5*20 mm 10 AT	841274

WEIGHMASTER 2448				
Description	Amount	Make	Specifications	Holten no.
Exhaust filter	2 pcs	Camfil	MDLA-GW-305x610x66-01 PU	95200501
Main filter	2 pcs	Camfil	MDLA-GW-305x610x66-01 PU	95200501
Light tube	1 pcs	Phillips	TLD 36/83	844027
Starter	1 pcs	Osram	ST111, 220-240 V-4-80W	844053
Fuse cut-out	1 pcs	Osram	5*20 mm 10 AT	841274

WEIGHMASTER 2460				
Description	Amount	Make	Specifications	Holten no.
Exhaust filter	1 pcs	Camfil	MDLA-GW-305x914x66-01 PU	95200513
	1 pcs	Camfil	MDLA-GW-305x610x66-01 PU	95200501
Main filter	1 pcs	Camfil	MDLA-GW-305x914x66-01 PU	95200513
	1 pcs	Camfil	MDLA-GW-305x610x66-01 PU	95200501
Light tube	1 pcs	Phillips	TLD 58/83	844028
Starter	1 pcs	Osram	ST 111, 220-240 V-4-80W	844053
Fuse cut-out	1 pcs	Osram	5*20 mm 10 AT	841274

WEIGHMASTER 2472				
Description	Amount	Make	Specifications	Holten no.
Exhaust filter	2 pcs	Camfil	MDLA-GW-305x914x66-01 PU	95200513
Main filter	2 pcs	Camfil	MDLA-GW-305x914x66-01 PU	95200513
Light tube	1 pcs	Phillips	TLD 58/83	844028
Starter	1 pcs	Osram	ST111, 220-240 V-4-80W	844053
Fuse cut-out	1 pcs	Osram	5*20 mm 10 AT	841274

WEIGHMASTER 2436 with prefilter				
Description	Amount	Make	Specifications	Holten no.
Prefilter	3 pcs	Sofiltra-Camfil	3326-01, VZ R2L	95400130
Exhaust filter	1 pcs	Camfil	MDLA-GW-305x914x66-01 PU	95200513
Main filter	1 pcs	Camfil	MDLA-GW-305x914x66-01 PU	95200513
Light tube	1 pcs	Phillips	TLD 30/83	844035
Starter	1 pcs	Osram	ST111, 220-240 V-4-80W	844053
Fuse cut-out	1 pcs	Osram	5*20 mm 10 AT	841274

WEIGHMASTER 2448 with prefilter				
Description	Amount	Mark	Specifications	Holten no.
Prefilter	4 pcs	Sofiltra-Camfil	3326-01, VZ R2L	95400130
Exhaust filter	2 pcs	Camfil	MDLA-GW-305x610x66-01 PU	95200501
Main filter	2 pcs	Camfil	MDLA-GW-305x610x66-01 PU	95200501
Light tube	1 pcs	Phillips	TLD 36/83	844027
Starter	1 pcs	Osram	ST111, 220-240 V-4-80W	844053
Fuse cut-out	1 pcs	Osram	5*20 mm 10 AT	841274

WEIGHMASTER 2460 with prefilter				
Description	Amount	Make	Specifications	Holten no.
Prefilter	5 pcs	Sofiltra-Camfil	3326-01, VZ R2L	95400130
Exhaust filter	1 pcs	Camfil	MDLA-GW-305x914x66-01 PU	95200513
	1 pcs	Camfil	MDLA-GW-305x610x66-01 PU	95200501
Main filter	1 pcs	Camfil	MDLA-GW-305x914x66-01 PU	95200513
	1 pcs	Camfil	MDLA-GW-305x610x66-01 PU	95200501
Light tube	1 psc	Phillips	TLD 58/83	844028
Starter	1 pcs	Osram	ST111, 220-240 V-4-80W	844053
Fuse cut-out	1 pcs	Osram	5*20 mm 10 AT	841274

WEIGHMASTER 2472 with prefilter				
Description	Amount	Mark	Specifications	Holten no
Prefilter	6 pcs	Sofiltra-Camfil	3326-01, VZ R2L	95400130
Exhaust filter	2 pcs	Camfil	MDLA-GW-305x914x66-01 PU	95200513
Main filter	2 pcs	Camfil	MDLA-GW-305x914x66-01 PU	95200513
Light tube	1 pcs	Phillips	TLD 58/83	844028
Starter	1 pcs	Osram	ST111, 220-240 V-4-80W	844053
Fuse cut-out	1 pcs	Osram	5*20 mm 10 AT	841274

13. Trouble-shooting

If none of the following attempts will bring the unit to operate satisfactorily a qualified service technician should be called in.

1.	☹ Problem	: The cabinet will not start and the light will not emit light.
	☺ Possible solution	: Check that the cabinet is connected to the wall socket; is this switched on? If necessary, try with other equipment to see whether there is normal voltage on the wall socket or not.
		The cabinet is equipped with a fuse cut-out placed in the electrical box in the right side of the top of the unit. Try changing this.
2.	☹ Problem	: The cabinet starts, but no light is emitted.
	☺ Possible solution	: Change starter and/or light tubes.
3.	☹ Problem	: The cabinet has started but the signal lamp for too little exhaust air is emitting light.
	☺ Possible solution	: Check that the suction holes in the tabletops are not covered and that the exhaust on top of the unit is not blocked.
		If there is exhaust to the outside the exhaust duct system may be blocked and the booster fan stopped.

14. Specific

14.1. Exhaust to the outside

Introduction:

The connection of cabinets to exhaust to the outside extraction systems involves some serious considerations.

In the following some considerations are put forward.



WARNING

Holten LaminAir takes no responsibility for accidents caused by insufficiently working "exhaust to the outside" extraction systems.

15. Considerations for exhaust to the outside system

Exhaust to the outside ducting systems:

- The exhaust system should minimise the effect on the cabinet of outdoor wind pressures. Up to 250 Pa at the end of the duct.
- The discharge opening should be sited so that the exhaust opening is not influenced by air movements around the building.
- The risk of exhaust air being drawn back into the building or other buildings through windows or air intakes should be considered.
- The extraction ductwork should be clearly marked and it should be possible to identify ductwork leading to a specific cabinet. So the ductwork should be cabinet specific. I.e. one extract system per cabinet. Sharing of ducts is not recommended.

- Ductwork should follow the most direct route to the discharge point, there should be a minimum of horizontal run and a minimum of bends.
- The exhaust fan should be situated apart from the cabinet and close to the discharge end of the duct so that only a minimum length of ducting is under positive pressure.

Make-up air systems:

- Cabinets should only be installed after first considering the type of make-up air system necessary to replace all of the air leaving the room through the cabinet. The air supply system must not compromise performance of the safety cabinet.
- For air make-up by passive air inflow, openings, louvers or transfer grilles should be provided in walls and doors for make-up air to be introduced into the room from the surroundings preferably from the adjacent heated corridors.

Special considerations for Holten Laminair Cabinets:

- Never draw air from the cabinet when the internal fan is not operating.
- In order to withstand back pressures in the ducting of 250 Pa we recommend that all Holten cabinets with extraction ducting should be equipped with separate exhaust fan.

Installation of exhaust to the outside systems:

The size of the exhaust stub on WEIGHMASTER and the nominal exhaust air volume are given in table 1.

	WEIGHMASTER 2436	WEIGHMASTER 2448	WEIGHMASTER 2460	WEIGHMASTER 2472
Diameter of stub	Ø 200 mm	Ø 200 mm	Ø 200 mm	Ø 200 mm
Exhaust air volume nominal	405 m ³ /h	540 m ³ /h	675 m ³ /h	810 m ³ /h

Table 1.

End remarks:

If you do not feel that you have a comfortable overview of all details we recommend that you obtain specialists advice, eg. your local Holten LaminAir agent or the technical department of Holten LaminAir.

We:

Heto-Holten A/S
Gydevang 17-19, DK-3450 Allerød
Denmark

declare under our sole responsibility that the product

Model: **Weighmaster**

to which this declaration relates is in conformity with the following standard(s) or other normative document(s):

EN 292-1:1991 Safety of machinery
(Basic concepts - General principles for design.
Basic terminology, methodology)

EN 292-2:1991 Safety of machinery
(Basic concepts - General principles for design.
Technical principles and specifications)

EN 60204-1:1999: Safety of machinery - Electrical equipment of machines
(General requirements)

EN 61010-1: 1993 Safety requirement for electrical equipment for measurement, control and laboratory use
(General requirements)

EN 50081-1:1992 and 50082-1:1997 Electromagnetic compatibility
(Generic emission / immunity standard - Residential, commercial and light industry)

EN 1050: 1996 Safety of machinery
(Principles for risk assessment)

following the provisions of:

Directive 98/37/EEC Machinery

Directive 73/23/EEC Low voltage

Directive 89/336/EEC Electromagnetic compatibility